

Fast Coupling for:

- Monitoring and control of pressure
- Venting
- Sampling Fluids

Advantages:

- Coupling at system pressure level
- Connection is leakproof before **piston valve** is open
- Simple connection to measurement, control and switching devices
- Self locking metal protective cap
- Minimizes introduction of contamination to hydraulic systems

Working Pressure:

- Max. working pressure 9000 PSI (630 bar)
For SKK type G, K and S the recommended working pressure of fitting manufacturer should be noted
- Connection under pressure up to 5800 PSI (400 bar) max.

Materials:

- Metal parts: Steel, Stainless Steel on request

• Seals:

Standard

V = FPM-VITON Temperature range - 4°F to +392°F
(- 20° C to +200° C)

Optional

P = NBR-BUNA Temperature range - 4°F to +195°F
(- 20° C to +90° C)

E = EPDM Ethylene Propylene (for Brake Fluid)
Temperature range - 40°F to +302°F
(- 40° C to + 150° C)

- Hose: Polyamide Temperature range -31°F to +212°F
(-35° C to +100° C)

Media:

- Suitable for hydraulic oils and other low viscosity mineral based fluids (Check compatibility of seal material)
- For use with other liquid or gaseous media please consult STAUFF for details

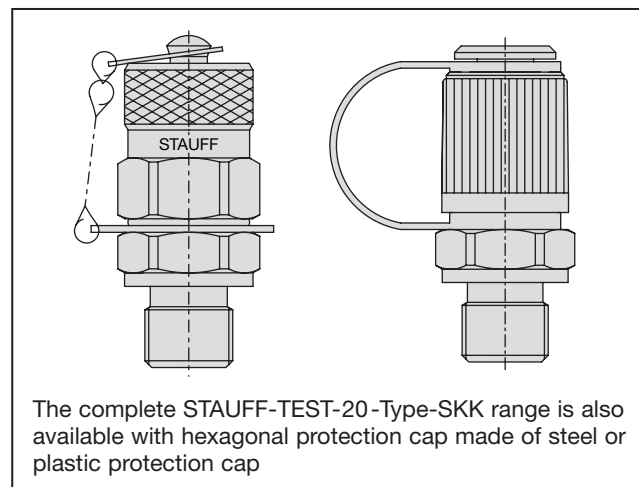

The complete STAUFF-TEST-20-Type-SKK range is also available with hexagonal protection cap made of steel or plastic protection cap



Test 20 Type SKK Connection Thread M 16 x 2

Test Coupling with Protective Cap SKK

Thread G	h		Hex		Order No.		Seal Type (see below)
	mm	in	mm	in	NBR (BUNA)	FPM (VITON) (Standard)	
M8 x 1	37	1.45	17	.67	SKK 20 - M8 x 1 - PA	SKK 20 - M8 x 1 - VA	O-Ring Type A
M10 x 1	37	1.45	17	.67	SKK 20 - M10 x 1 - PA	SKK 20 - M10 x 1 - VA	O-Ring Type A
M12 x 1,5	37	1.45	17	.67	SKK 20 - M12 x 1,5 - PC	SKK 20 - M12 x 1,5 - VC	O-Ring Type C
M14 x 1,5	37	1.45	19	.75	SKK 20 - M14 x 1,5 - PB	SKK 20 - M14 x 1,5 - VB	Metal joint Type B
M16 x 1,5	37	1.45	22	.87	SKK 20 - M16 x 1,5 - PB	SKK 20 - M16 x 1,5 - VB	Metal joint Type B
G 1/8	39	1.53	17	.67	SKK 20 - G 1/8 - PC	SKK 20 - G 1/8 - VC	O-Ring Type C
G 1/4	37	1.45	19	.75	SKK 20 - G 1/4 - PB	SKK 20 - G 1/4 - VB	Metal joint Type B
G 1/4	37	1.45	19	.75	SKK 20 - G 1/4 - PC	SKK 20 - G 1/4 - VC	O-Ring Type C
G 3/8	37	1.45	22	.87	SKK 20 - G 3/8 - PB	SKK 20 - G 3/8 - VB	Metal joint Type B
R 1/8 taper	37	1.45	17	.67	SKK 20 - R 1/8 K-PD	SKK 20 - R 1/8 K-VD	Taper Type D
R 1/4 taper	36	1.41	17	.67	SKK 20 - R 1/4 K-PD	SKK 20 - R 1/4 K-VD	Taper Type D
1/8 NPT	36	1.41	17	.67	SKK 20 - 1/8 NPT-PD	SKK 20 - 1/8 NPT-VD	Taper Type D
1/4 NPT	35	1.38	17	.67	SKK 20 - 1/4 NPT-PD	SKK 20 - 1/4 NPT-VD	Taper Type D
5/16 - 24 UNF	38	1.50	17	.67	SKK 20 - 5/16 UNF-PE	SKK 20 - 5/16 UNF-VE	O-Ring Type E
7/16 - 20 UNF	38	1.50	17	.67	SKK 20 - 7/16 UNF-PE	SKK 20 - 7/16 UNF-VE	O-Ring Type E
1/2 - 20 UNF	38	1.50	17	.67	SKK 20 - 1/2 UNF-PE	SKK 20 - 1/2 UNF-VE	O-Ring Type E
9/16 - 18 UNF	37	1.45	19	.75	SKK 20 - 9/16 UNF-PE	SKK 20 - 9/16 UNF-VE	O-Ring Type E

To order hexagonal protection cap, add "SK" to part number. To order Plastic Protection cap, add "KK" to part number.
Other port connections and seals on request.

TEST

Port Connections and Seals

Type A				Type B					Type C					Type D			Type E (ISO 6149)						
G	d ₁	t ₁	t ₂	G	d ₁	t ₁	t ₂	a	G	d ₁	t ₁	t ₂	a	G	t ₁	t ₂	G	d ₁	d ₂	t ₁	t ₂	a	
	mm	mm	mm		mm	mm	mm	mm		mm	mm	mm	mm		mm	mm	mm		mm	mm	mm	mm	mm
	in	in	in		in	in	in	in		in	in	in	in		in	in	in		in	in	in	in	in
M8 x 1	9,5 + 0,1	11	15,5	M14 x 1,5	20	12	18,5	1,5	M12 x 1,5	18	12	18,5	1,5	R 1/8 taper	5,5	9,5	5/16 - 24 UNF	9,1	17	10	12	1,9	
	0,37	0,43	0,61		0,79	0,47	0,73	0,06		0,71	0,47	0,73	0,06		0,22	0,37		0,36	0,67	0,39	0,47	0,07	
M10 x 1	11,5 + 0,1	12	16,5	M16 x 1,5	22	12	18,5	1,5	G 1/8	15	8	13	1,0	R 1/4 taper	8,5	13,5	7/16 - 20 UNF	12,4	21	11,5	14	2,4	
	0,45	0,47	0,65		0,87	0,47	0,73	0,06		0,59	0,31	0,51	0,04		0,33	0,53		0,49	0,83	0,45	0,55	0,09	
				G 1/4	19	12	18,5	1,5	G 1/4	19	12	18,5	1,5	1/8 NPT	6,9	11,6	1/2 - 20 UNF	14	23	11,5	14	2,4	
					0,75	0,47	0,73	0,06		0,75	0,47	0,73	0,06	1/4 NPT	10	16,4		0,55	0,91	0,45	0,55	0,09	
				G 3/8	23	12	18,5	1,5							0,39	0,65	9/16 - 18 UNF	15,6	25	12,7	15,5	2,5	
					0,91	0,47	0,73	0,06										0,61	0,98	0,50	0,61	0,10	



Test 20 Type SKK Connection Thread M 16 x 2

Test Coupling SKK (compression ring fittings acc. to DIN 2353) - Metric Tubing

TEST

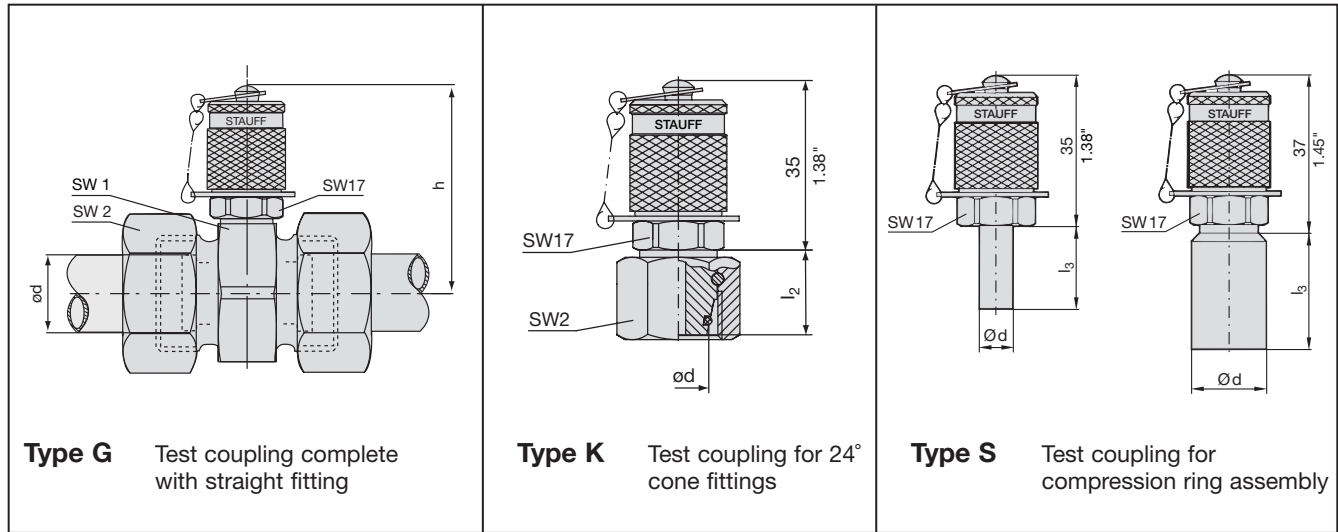

Type G Test coupling complete with straight fitting

Type K Test coupling for 24° cone fittings

Type S Test coupling for compression ring assembly

Series	PN PSI (Bar)	Pipe Ød	l ₂		l ₃		h		SW 1		SW 2		Order No.*		
			mm	in	mm	in	mm	in	mm	in	mm	in	Type G	Type K	Type S
L	4500 (315)	6	15,5	0.61	20	0.79	49	1.93	24	0.94	14	0.55	SKK 20 - 6L-VG	SKK 20 - 6L-VK	SKK 20 - 6-VS
		8	15,5	0.61	20	0.79	49	1.93	24	0.94	17	0.67	SKK 20 - 8L-VG	SKK 20 - 8L-VK	SKK 20 - 8-VS
		10	16,5	0.65	22	0.87	49	1.93	24	0.94	19	0.75	SKK 20 - 10L-VG	SKK 20 - 10L-VK	SKK 20 - 10-VS
		12	17,5	0.69	22	0.87	50	1.97	27	1.06	22	0.87	SKK 20 - 12L-VG	SKK 20 - 12L-VK	SKK 20 - 12-VS
		15	21	0.83	25	0.98	52	2.05	30	1.18	27	1.06	SKK 20 - 15L-VG	SKK 20 - 15L-VK	SKK 20 - 15-VS
		18	19,5	0.77	28	1.10	53	2.09	32	1.26	32	1.26	SKK 20 - 18L-VG	SKK 20 - 18L-VK	SKK 20 - 18-VS
	2300 (160)	22	20,5	0.81	30	1.18	55	2.17	36	1.42	36	1.42	SKK 20 - 22L-VG	SKK 20 - 22L-VK	SKK 20 - 22-VS
		28	25	0.98	32	1.26	57,5	2.26	41	1.61	41	1.61	SKK 20 - 28L-VG	SKK 20 - 28L-VK	SKK 20 - 28-VS
		35	30	1.18	42	1.65	60	2.36	46	1.81	50	1.97	SKK 20 - 35L-VG	SKK 20 - 35L-VK	SKK 20 - 35-VS
		42	31	1.22	45	1.77	64,5	2.54	55	2.17	60	2.36	SKK 20 - 42L-VG	SKK 20 - 42L-VK	SKK 20 - 42-VS
S	9100 (630)	6	14,5	0.57	20	0.79	49	1.93	24	0.94	17	0.67	SKK 20 - 6S-VG	SKK 20 - 6S-VK	SKK 20 - 6-VS
		8	16,5	0.65	20	0.79	49	1.93	24	0.94	19	0.75	SKK 20 - 8S-VG	SKK 20 - 8S-VK	SKK 20 - 8-VS
		10	16,5	0.65	22	0.87	49	1.93	24	0.94	22	0.87	SKK 20 - 10S-VG	SKK 20 - 10S-VK	SKK 20 - 10-VS
		12	17,5	0.69	22	0.87	49	1.93	24	0.94	24	0.94	SKK 20 - 12S-VG	SKK 20 - 12S-VK	SKK 20 - 12-VS
		14	19,5	0.77	22	0.87	50,5	1.99	27	1.06	27	1.06	SKK 20 - 14S-VG	SKK 20 - 14S-VK	SKK 20 - 14-VS
	5800 (400)	16	18	0.71	28	1.10	52	2.05	30	1.18	30	1.18	SKK 20 - 16S-VG	SKK 20 - 16S-VK	SKK 20 - 16-VS
		20	24	0.94	30	1.18	55	2.17	36	1.42	36	1.42	SKK 20 - 20S-VG	SKK 20 - 20S-VK	SKK 20 - 20-VS
		25	26	1.02	36	1.42	57,5	2.26	41	1.61	46	1.81	SKK 20 - 25S-VG	SKK 20 - 25S-VK	SKK 20 - 25-VS
		30	30	1.18	41	1.61	60	2.36	46	1.81	50	1.97	SKK 20 - 30S-VG	SKK 20 - 30S-VK	SKK 20 - 30-VS
		4500 (315)	38	34	1.34	48	1.89	64,5	2.54	55	2.17	60	2.36	SKK 20 - 38S-VG	SKK 20 - 38S-VK

* For ordering BUNA seals please replace "V" with "P"

* For EPDM seals replace "V" with "E"